

**Jordan University of Science and Technology**

*Electrical Engineering Department*



Done By: *Ahmad Jisrawi*

Supervised By: *Dr. Nihad Dib*

## Table of Contents

Introduction .....	2
Mobile Jamming and Disablers Techniques.....	3
GSM-Mobile JAMMING Requirements.....	7
Design and Implementation of GSM Mobile JAMMER.....	11
RF-Section .....	11
Voltage controlled oscillator.....	12
RF-Power Amplifier.....	13
Antenna.....	15
IF-Section.....	18
Triangular wave generator.....	18
Noise Generator.....	20
Signal mixer and DC-offset Circuit.....	21
Power Supply.....	24
Conclusions.....	26
References.....	27

## INTRODUCTION

A GSM Jammer is a device that transmit signal on the same frequency at witch the GSM system operates, the jamming success when the mobile phones in the area where the jammer is located are disabled.

Communication jamming devices were first developed and used by military. Where tactical commanders use RF communications to exercise control of their forces, an enemy has interest in those communications. This interest comes from the fundamental area of denying the successful transport of the information from the sender to the receiver.

Nowadays the mobile jammer devices are becoming civilian products rather than electronic warfare devices, since with the increasing number of the mobile phone users the need to disable mobile phones in specific places where the ringing of cell phone would be disruptive has increased. These places include worship places, university lecture rooms, libraries, concert halls, meeting rooms, and other places where silence is appreciated.

Mosques are example for the places were mobile jammer would be a great solution, although mosques asks politely from prayers to disable their mobile phone during the prayer ,see figure (1), some people forget and the ringing phone of their mobile phone become very annoying specially during the praying time.



Figure 1: Typical sign used in places where mobile phone are not allowed

## **Mobile Jamming and Disablers Techniques**

There are different approaches to prevent mobile phones from ringing in specific area, the main five approaches used or being developed are described in RABC Mobile & Personal Communications Committee's (M&PCC) meeting of June 22, 1999 [1], these techniques are summarized in this section :

### **1- Type "A" Device**

In this device we overpower cell phone's signal with a stronger signal, This type of device comes equipped with several independent oscillators transmitting 'jamming signals' capable of blocking frequencies used by paging devices as well as those used by cellular/PCS systems' control channels for call establishment. When active in a designated area, such devices will (by means of RF interference) prevent all pagers and mobile phones located in that area from receiving and transmitting calls. This type of device transmits only a jamming signal and has very poor frequency selectivity, which leads to interference with a larger amount of communication spectrum than it was originally intended to target.

Technologist Jim Mahan said, "There are two types. One is called brute force jamming, which just blocks everything. The problem is, it's like power-washing the airwaves and it bleeds over into the public broadcast area. The other puts out a small amount of interference, and you could potentially confine it within a single cell block. You could use lots of little pockets of small jamming to keep a facility under control."

### **2- Type "B" Device**

This device also called "Intelligent Cellular Disablers devices", and it does not transmit an interfering signal on the control channels. The device basically works as a detector, and it capable to communicate with the cellular base station. When the

device detects the presence of a mobile phone in the "silent" room; a prevention of authorization of call establishment is done by the software at the base station. The device signals the base station that the target user is in a 'quiet' room; therefore, do not establish the communication. Messages can be routed to the user's voice- mail box, if the user subscribes to a voice- mail service. This process of detection and interruption of call establishment is done during the interval normally reserved for signaling and handshaking.

This intelligent device as it's name imply can recognize emergency calls and also can allow specific pre-registered users to use their mobile phones for a specified duration. Although this device sounds the best solution for disabling mobile phone, a provision is needed by the cellular/PCS service providers or provision by a third-party working cooperatively with full support of the cellular/PCS service providers, allowing the detector device to be integral part of the cellular/PCS systems.

### **3- Type "C" Device**

This device also called "Intelligent Beacon Disablers ", as in the type "B" device it does not transmit an interfering signal on the control channels.

The device, when located in a specific "silent" room, functions as a 'beacon' and any compatible terminal is ordered to disable its ringer or disable its operation. In the coverage area of the beacon only terminals which have a compatible receiver would respond and this should be built on a separate technology from cellular/PCS, for example Bluetooth technology. Also the handset must re-enable its normal function as it leaves the coverage area of the beacon.

The need for intelligent handsets with a separate receiver for the beacon receiver from the cellular/PCS receiver, make effective deployment for the type "C" device will be problematic for many years.

#### **4- Type "D" Device**

This jammer is similar to type "A" , but with a receiver, so that jammer is predominantly in receive mode and when the device detects the presence of a mobile phone in the "silent" room; it will intelligently choose to interact and block the cell phone by transmitting jamming signal. This jam signal would only stay on as long as the mobile continues to make a link with the base station; otherwise there would be no jamming transmission.

Thus this device much less electromagnetic pollution in terms of raw power transmitted and frequency spectrum from the type "A" Jammer, and therefore much less disruptive to passing traffic. This technique could be implemented without cooperation from PCS/cellular providers. Also this technique has an added advantage over Type B in that no added overhead time or effort is spent negotiating with the cellular network.

#### **5- Type "E" Device**

This technique is using EMI suppression techniques to make a room into what is called a Faraday cage. Although labour intensive to construct, the Faraday cage essentially blocks, or greatly attenuates, virtually all electromagnetic radiation from entering or leaving the cage or in this case a target room.

With current advances in EMI shielding techniques and commercially available products one could conceivably implement this into the architecture of newly designed buildings for so-called "quiet-conference" rooms.

Emergency calls would be blocked unless there was a way to receive and decode the Emergency Call transmissions, pass by coax outside the room and re-transmitted.

This passive configuration is currently legal in most worlds' countries for any commercial or residential location; however some building may not allow this type of construction. Table 1 shows a comparison between the different Jammer/Disablers techniques.

Type	Emergency call	Efficiency	Regularity Approval	Implementation
"A"	Blocked	Low	Not allowed	Very simple
"B"	Allowed	Medium	Required	Complex (Required third party Cellular/PCS Services)
"C"	Allowed	High	Required	Complex (Required Intelligent Handset)
"D"	Allowed	Medium	Required	Simple
"E"	Blocked	High(No signal transmitted)	Allowed	Simple

Table 1: Comparison between Jammer/Disabler Techniques

## GSM-Mobile JAMMING Requirements

As discussed in part-2, jamming objective is to inject an interference signal into the communications frequency so that the actual signal is completely submerged by the interference. It is important to notice that transmission can never be totally jammed - jamming hinders the reception at the other end. The problem here for the jammer is that only transmitters can be found using direction finding and the location of the target must be a specific location, usually where the jammer is located and this is because the jamming power is never infinite.

Jamming is successful when the jamming signal denies the usability of the communications transmission. In digital communications, the usability is denied when the error rate of the transmission cannot be compensated by error correction. Usually a successful jamming attack requires that the jammer power is roughly equal to signal power at the receiver.

The effects of jamming depend on the jamming-to-signal ratio (J/S), modulation scheme, channel coding and interleaving of the target system.

Generally Jamming-to-Signal ratio can be measured according to the following Equation. [2]

$$\frac{J}{S} = \frac{P_j G_{jr} G_{rj} R_{tr}^2 L_r B_r}{P_t G_{tr} G_{rt} R_{jr}^2 L_j B_j}$$

Where:

$P_j$  = jammer power

$P_t$  = transmitter power

$G_{jr}$  = antenna gain from jammer to receiver

$G_{rj}$  = antenna gain from receiver to Jammer

$G_{tr}$  = antenna gain from transmitter to receiver

$G_{rt}$  = antenna gain from receiver to transmitter



$B_r$  = communications receiver bandwidth

$B_j$  = jamming transmitter bandwidth

$R_{tr}$  = range between communications transmitter and receiver

$R_{jt}$  = range between jammer and communications receiver

$L_j$  = jammer signal loss (including polarization mismatch)

$L_r$  = communication signal loss

The above Equation indicates that the jammer Effective Radiated Power, which is the product of antenna gain and output power, should be high if jamming efficiency is required. On the other hand, in order to prevent jamming, the antenna gain toward the communication partner should be as high as possible while the gain towards the jammer should be as small as possible. As the equation shows, the antenna pattern, the relation between the azimuth and the gain, is a very important aspect in jamming.

Also as we know from Microwave and shown in the equation distance has a strong influence on the signal loss. If the distance between jammer and receiver is doubled, the jammer has to quadruple its output in order for the jamming to have the same effect. It must also be noted here that jammer path loss is often different from the communications path loss; hence gives jammer an advantage over communication transmitters.

In the GSM network, the Base Station Subsystem (BSS) takes care of the radio resources. In addition to Base Transceiver Station (BTS), the actual RF transceiver, BSS consists of three parts. These are the Base Station Controller (BSC), which is in charge of mobility management and signaling on the Air-interface between Mobile Station (MS), the BTS, and the Air-interface between BSS and Mobile Services Switching Center (MSC).

The GSM Air-interface uses two different multiplexing schemes: TDMA (Time Division Multiple Access) and FDMA (Frequency Division Multiple Access). The spectrum is divided into 200 kHz channels (FDMA) and each channel is divided into 8 timeslots (TDMA). Each 8 timeslot TDMA frame has duration of 4.6 ms (577 s/timeslot) [3]. The GSM transmission frequencies are presented in Table 2

	Uplink	Downlink
GSM 900	890-915 MHz	935-960 MHz

Table 2: GSM 900 Frequency Band

Frequency Hopping in GSM is intended for the reduction of fast fading caused by movement of subscribers. The hopping sequence may use up to 64 different frequencies, which is a small number compared to military FH systems designed for avoiding jamming. Also, the speed of GSM hopping is approximately 200 hops / s; So GSM Frequency Hopping does not provide real protection against jamming attacks.

Although FH doesn't help in protection against jamming, interleaving and forward error correction scheme GSM Systems can protect GSM against pulsed jamming. For GSM it was shown that as the specified system  $SNR_{min}$  is 9 dB [3], a jammer requires a 5 dB S/J in order to successfully jam a GSM channel. The optimum GSM SNR is 12 dB, after this point the system starts to degrade.

GSM system is capable to withstand abrupt cuts in Traffic Channel (TCH) connections. These cuts are normally caused by propagation losses due to obstacles such as bridges. Usually another cell could be used to hold communication when the original BTS has disconnected. The GSM architecture provides two solutions for this: first handover when the connection is still available, second call re-establishment when the original connection is totally lost. Handover decisions are

made based on transmission quality and reception level measurements carried out by the MS and the BTS. In jamming situations call re-establishment is probably the procedure the network will take in order to re-connect the jammed TCH.

It is obvious that downlink jamming (i.e. Jamming the mobile station 'handset' receiver) is easier than uplink, as the base station antenna is usually located far a way from the MS on a tower or a high building. This makes it efficient for the jammer to overpower the signal from BS. But the Random Access Channel (RACH) control channels of all BTSs in the area need to be jammed in order to cut off transmission. To cut an existing connections, the jamming has to last at least until the call re-establishment timer at the MSC expires and the connection is released, which means that an existing call can be cut after a few seconds of effective jamming.

The GSM RACH random access scheme is very simple: when a request is not answered, the mobile station will repeat it after a random interval. The maximum number of repetitions and the time between them is broadcast regularly. After a MS has tried to request service on RACH and has been rejected, it may try to request service from another cell. Therefore, the cells in the area should be jammed. In most cases, the efficiency of a cellular jamming is very difficult to determine, since it depends on many factors, which leaves the jammer confused.

## Design and Implementation of GSM Mobile JAMMER

The Implementation of type "A" JAMMER is fairly simple, the block diagram for this type is shown in figure (2), it shows the main parts which are: RF-section, IF-section, and the power supply.

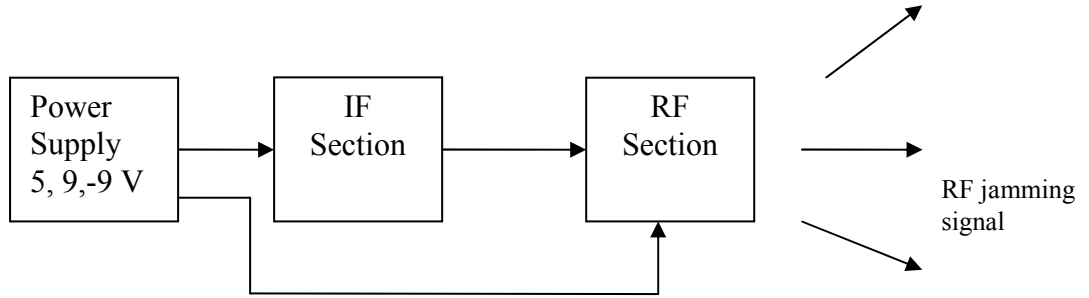

Figure 2: Block diagram of the mobile Jammer

### 1-RF-Section:

The RF-section is the most important part of the mobile jammer it consist of the Voltage Controlled Oscillator (VCO), RF Power amplifiers, and the antenna. These components were selected according to the desired specification of the jammer such as the frequency range and the coverage range. Its important to note that all the components used has 50 ohm input/output impedance, so 50 ohm microstrip was needed for matching between the components. The width of the microstrip was calculated using the following Equations for  $w/h > 1$ : [4]

$$Z_0 = \frac{120\pi}{\sqrt{\epsilon_{eff}}} \cdot \frac{1}{\left( \frac{w}{h} + 1.393 + 0.677 \cdot \ln\left( \frac{w}{h} + 1.444 \right) \right)}$$

$$\epsilon_{eff} = \left[ \frac{\epsilon_r + 1}{2} + \frac{\epsilon_r - 1}{2} \left[ \frac{1}{\sqrt{1 + \frac{12h}{w}}} \right] \right]$$

To obtain the desired output jamming power for coverage range of 20 m first we found he jamming power required at the mobile receiver "Jr", knowing that  $SNR_{min} = 9$  dB and  $S_{max} = -15$ dBm (i.e. worst jamming case).[5] then from

$SNR_{min} = S/J$ , where S = the signal power, J = the jamming power

$J_r = -24dBm$ , then by invoking the free space path loss equation: [6]

$F = 32.45 + 20 \log(f \cdot D)$ , where "Ds" is distance in Km and "f" is frequency in MHz ,

for 20 m the loss equals 58 dB hence the jammer should transmit a jamming signal with power equals : 58 dB -24dBm = 34dBm, to sustain a 20m jamming area.

### 1.1 - Voltage Controlled Oscillator:

The VCO is responsible for generating the RF signal which will over power the mobile downlink signal. The selection of the VCO was influenced by two main factors, the frequency of the GSM system, which will be jammed and the availability of the chip. For the first factor which implies that the VCO should cover the frequencies from 935 MHz to 960 MHz, The MAX2623 VCO from MAXIM IC was found to be a good choice, and fortunately the second factor was met sequentially since MAXIM IC was willing to send two of the MAX2623 for free.

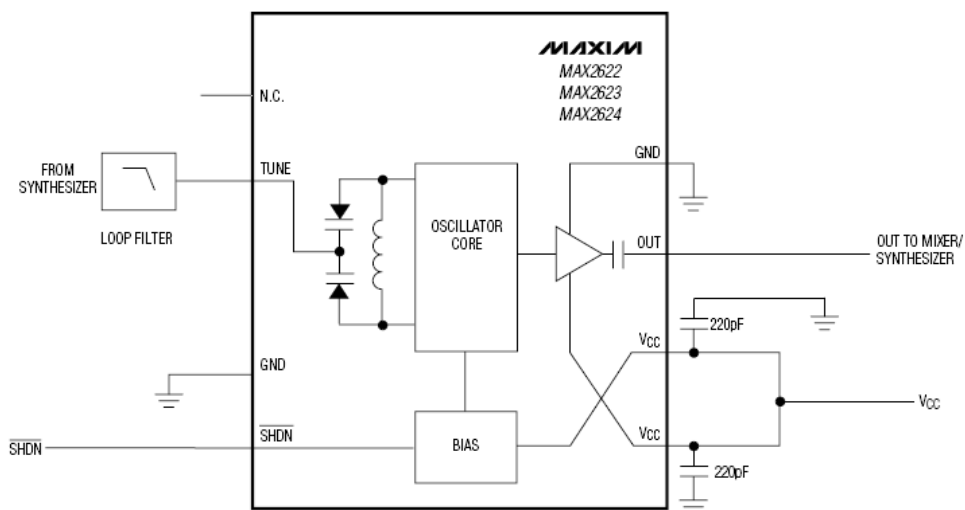
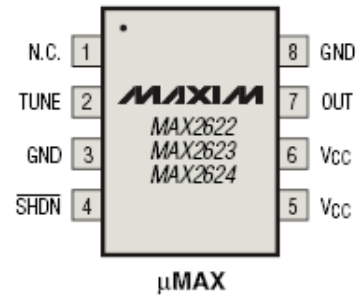

Figure 3: Maxim2623 typical connection

The MAX2623 VCO is implemented as an LC oscillator configuration, integrating all of the tank circuitry on-chip, this makes the VCO extremely easy-

to-use, and the tuning input is internally connected to the varactor as shown in figure (3). The typical output power is -3dBm, and the output was best swept over the desired range when the input tuning voltage was around 120 KHz.

## 1.2 - RF Power Amplifier

To achieve the desired output power a gain stages was needed, about searching for a suitable power amplifier I found that its easier and cheaper to look for power amplifier from an old Mobile phones. The PF08103B Hitachi power amplifier



module from NOKIA mobile phone was sufficient to amplify an input signal in the range 800MHz to 1GHz by 34 dB. But its recommend in the data sheet that the power at the input should be 1dBm. To meet this requirement I used another power amplifier stage after

the VCO and before the Hitachi Power Amplifier module, for this stage I used the MAR-4SM power amplifier from Mini-Circuits Company, the MAR-4SM has a typical gain of 8 dB for the frequencies range from dc to 1 GHz, so the output after this stage should be around 5dBm. A Typical biasing Configuration for the MAR-4SM is shown in figure (4),the bias current is delivered from a voltage supply Vcc (+9V in this design) through the resistor Rbias

and the RF choke (inductor). The effect of the resistor is to reduce the effect of device voltage (Vc) variation on the bias current by so simulating a current source. Blocking



capacitors are needed at the input and output ports. To prevent stray coupling to other signal processing components we use a bypass capacitor at the connection to the DC supply.

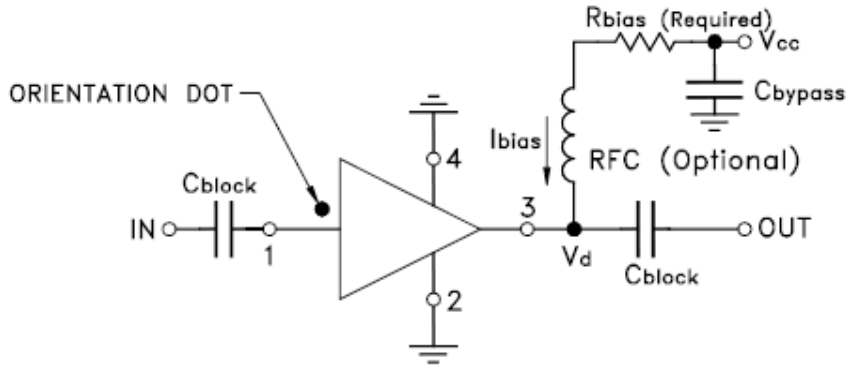

Figure 4: Typical biasing Configuration for the MAR-4SM

The bias current is given by the following equation:

$$I_{bias} = (V_{cc} - V_d) / R_{bias}$$

The design for the MAR amplifier was carried on a useful program form

AGILENT TECHNOLOGIES called APPCAD, the results are shown in figure 5

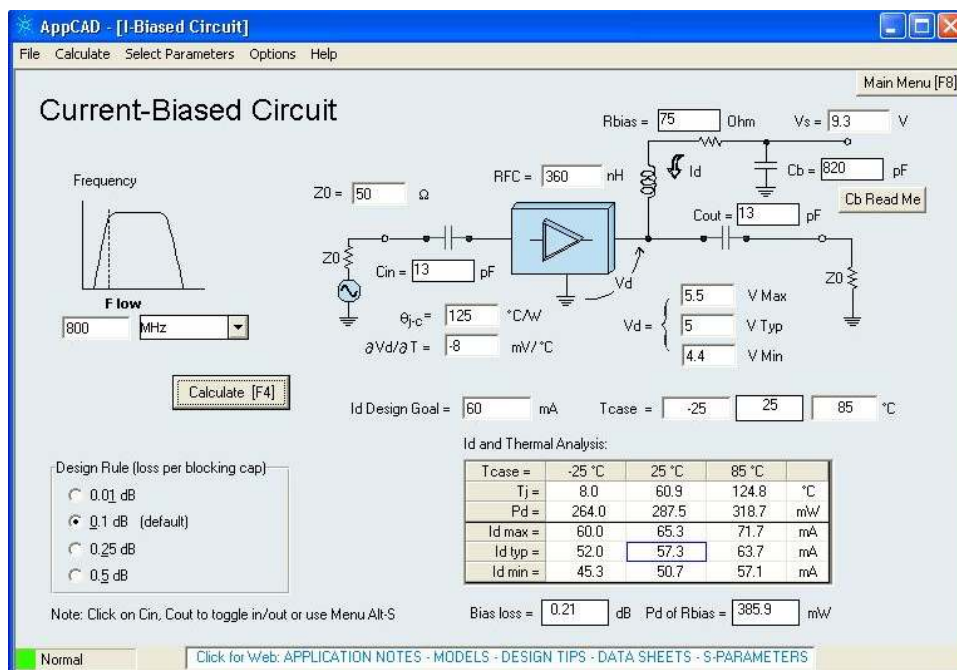

Figure 5: Biasing MAR-4SM

Now the power before the Hitachi RF amplifier is 5dBm and since 1dBm is required; I used 4dB T-Network attenuator as shown in figure (6). [7] The attenuator also designed to have 50 ohm characteristic impedance to easily match the whole circuits.

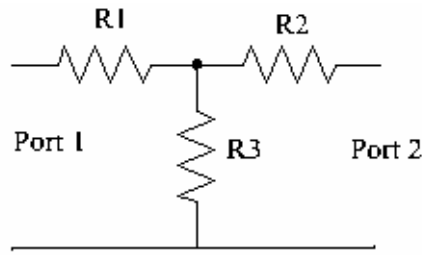

Figure 6: T-Network Attenuator

For 4-dB attenuation and symmetric Network  $S_{12} = S_{21} = 0.631$

(i.e.  $V_2^- = V_2 = 0.631 * V_1^-$ ), and for 50 ohm characteristic impedance we

found the values of the resistors using the following equations:

$$50 = (R2 + 50) // (R3) + R1$$

$$0.631 = (X / (X + R1)) * (50 / (50 + R1)), \text{ where } X = (R2 + 50) // R3.$$

### 1.3 - Antenna

The most important part of any transmitter is the antenna, so a suitable antenna should be selected.

The antenna used in this project is 1/4 wave

monopole antenna, and it has 50 Ohm impedance

so that the antenna is matched to the transmission

system. Also this antenna has low VSWR less

than 1.7, and a bandwidth of 150 MHz around

916 MHz center frequency which cover the mobile jammer frequency range.

The antenna gain is 2dBi. The patterns for the antenna are shown below:

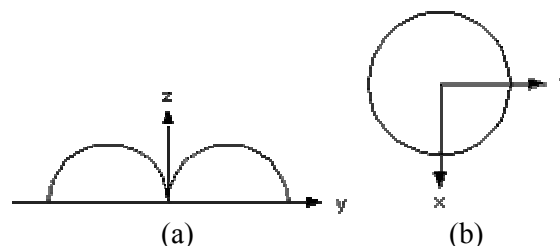
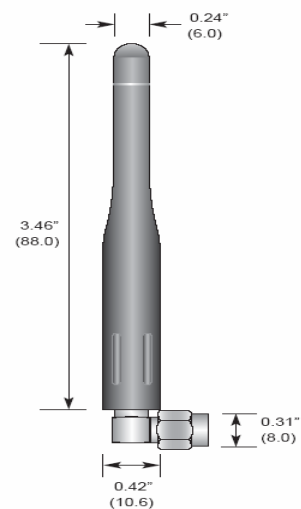

Figure 7: (a) Monopole Principal E-plane Pattern  
 (b) Monopole Principal H-plane Pattern  
 (Source: www.rfcafe.com)



Figure (8) shows the output of the VCO after the two RF amplifiers using the spectrum analyzer, and as shown it is tuned to sweeps from 625 – 960 MHz

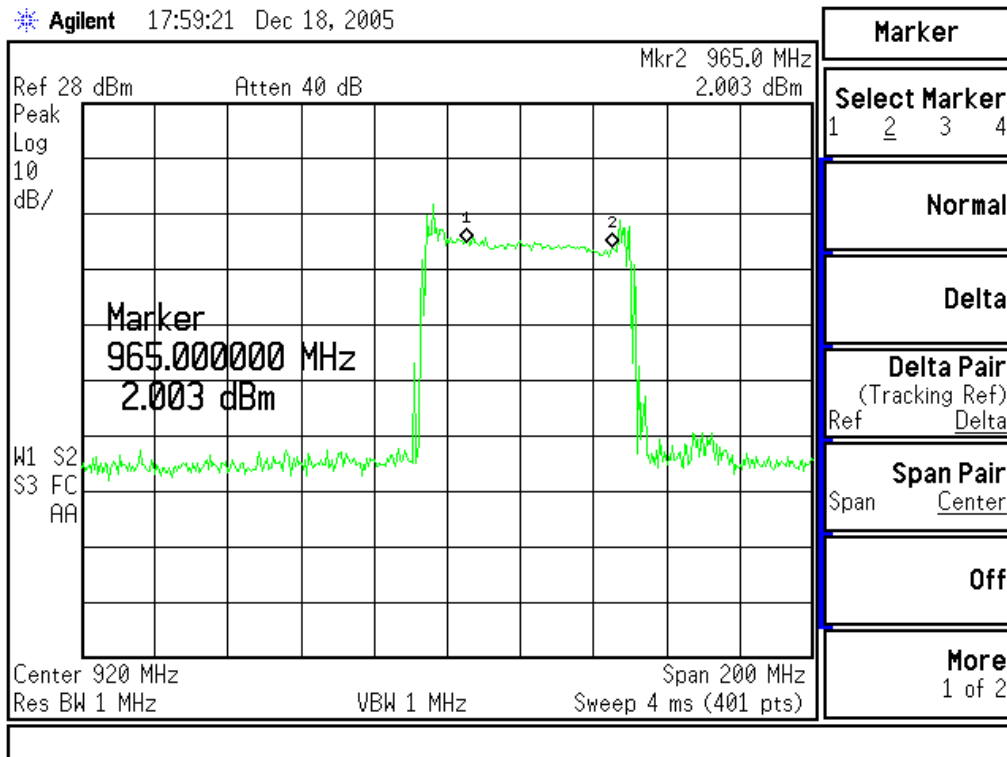

Figure 8: output of the mobile jammer

It is important to note that the RF-Section was implemented on FR-4 printed circuit board (PCB) with thickness of 1/32 inches. Also RF layout issues such as good grounding, transmission lines, and vias was taken into consideration when designing the layout for the RF-Section. Figure (9) shows the finished PCB of the RF-Section.

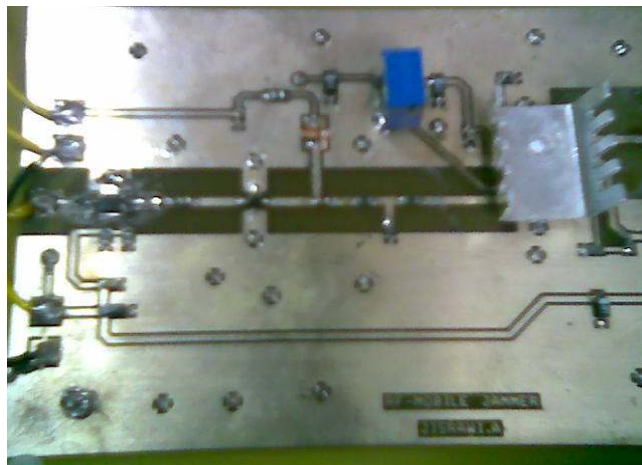

Figure 9: PCB of RF section of the mobile jammer

The Circuit Diagram for the RF-section was done using Orcad Capture, and it is shown in figure (10)

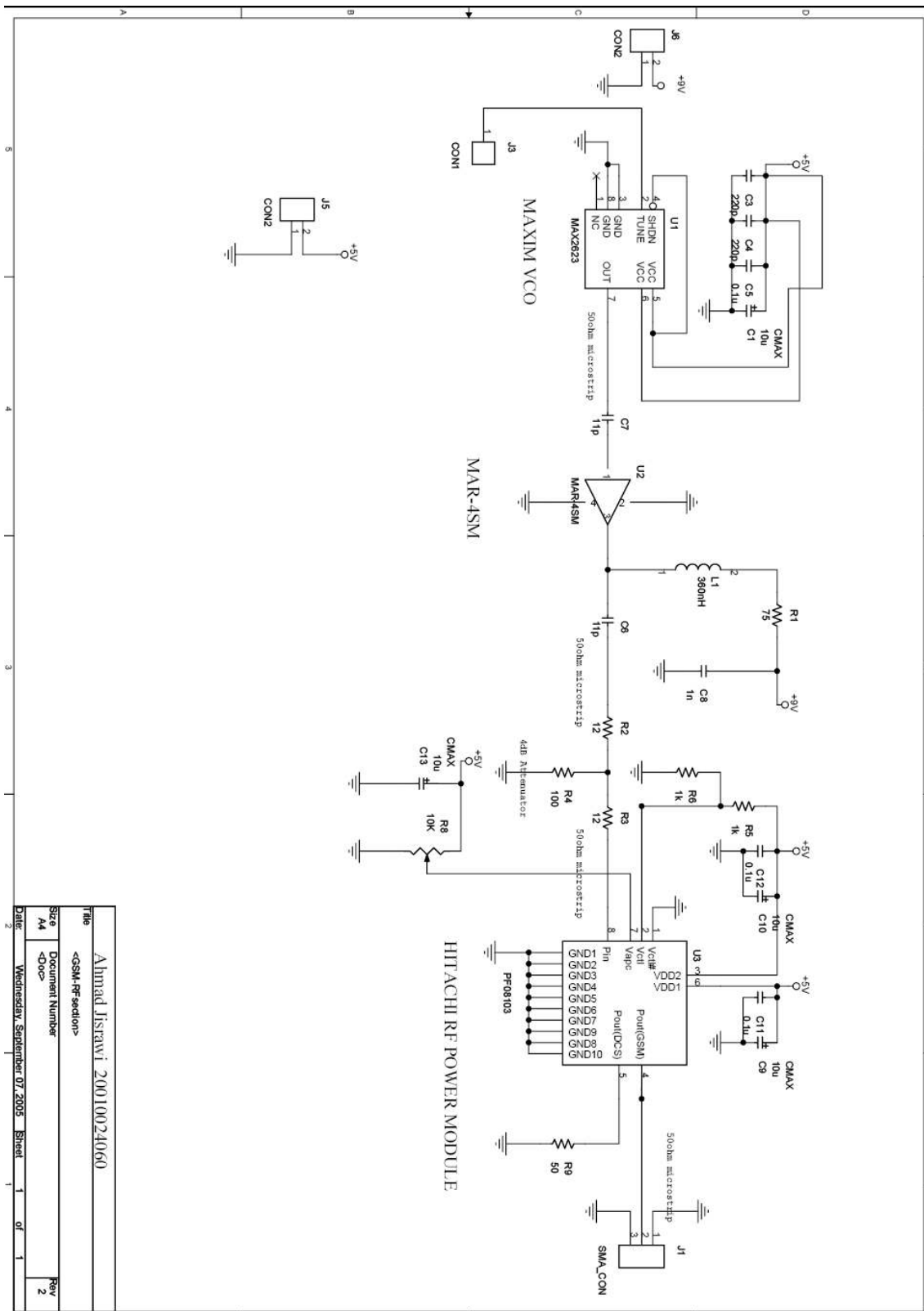

Figure 10: Circuit diagram for the RF-Section

## 2-IF-Section:

The function of the IF-section of the Mobile jammer is to generate the tuning signal for the VCO in The RF-Section, which will sweep the VCO through the desired range of frequencies. This tuning signal is generated by a triangular wave generator along with noise generator, and then offset by proper amount so as to sweep the VCO output from the minimum desired frequency to a maximum.

### 2.1- Triangular Wage Generator:

In the first revision for the mobile jammer I used operational amplifiers as relaxation oscillator to produce square wave generator and another OP-Amp as integrator to produce the desired triangular waveform, but since the gain-bandwidth for most OP-Amp is low the maximum output frequency was around 20 KHz which was not sufficient to sweep the MAXIM-VCO. The solution for this was to use 555-Timer as ASTABLE MULTIVIBRATOR. [8]

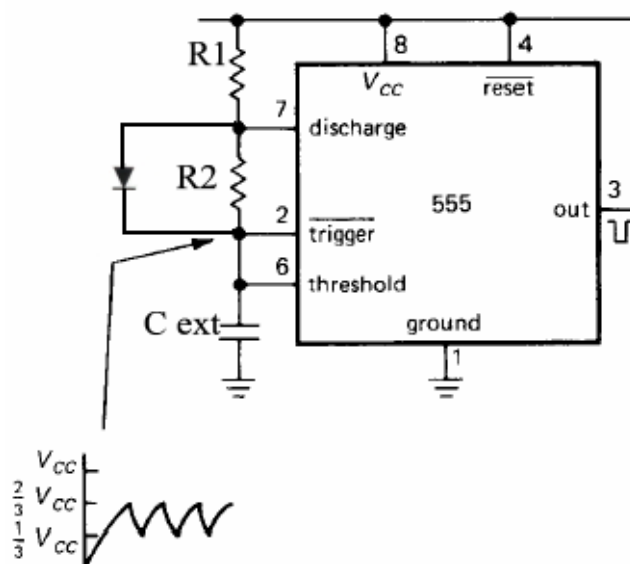

Figure 11: 555 timer connected as oscillator

The 555 timer consists basically of two comparators, a flip-flop, a discharge transistor, and a resistive voltage divider. The resistive divider is used to set the voltage comparator levels all three comparator levels.

A 555 timer connected to operate in the astable mode as a free-running nonsinusoidal oscillator (astable multivibrator) is shown in Figure (11). The threshold input is connected to the trigger input. The external components  $R_1$ ,  $R_2$ , and  $C_{ex}$  form the timing circuit that sets the frequency of oscillation. The 0.01  $\mu\text{F}$  capacitor connected to the control input is strictly for decoupling and has no effect on the operation; in some cases it can be left off. Initially, when the power is turned on, the capacitor  $C_{ext}$  is uncharged and thus the trigger voltage (pin 2) is at 0 V. This causes the output of the lower comparator to be high and the output of the upper comparator to be low, forcing the output of the flip-flop, and thus the base of  $Q_d$ , low and keeping the transistor off. Now,  $C_{ext}$  begins charging through  $R_1$  &  $R_2$  (to obtain 50% duty cycle, one can connect a diode parallel with  $R_2$  and choose  $R_2 = R_1$ ). When the capacitor voltage reaches  $1/3V_{CC}$ , the lower comparator switches to its low output state, and when the capacitor voltage reaches  $2/3V_{CC}$  the upper comparator switches to its high output state. This resets the flip flop causes the base of  $Q_d$  to go high, and turns on the transistor. This sequence creates a charge path for the capacitor through  $R_2$  and the transistor, as indicated. The cap now begins to discharge, causing the upper comparator to go low. At the point when capacitor discharges down to  $1/3V_{CC}$ , the lower comparator switches high, setting the flip flop, which makes the base of  $Q_d$  low and turns off the transistor. Another charging cycles begins, and the entire process repeats. The result is a rectangular wave output whose

duty cycle depends on the values of  $R_1$  and  $R_2$ . The frequency of oscillation is given by the following formula:

$$f_r = \frac{1.44}{(R_1 + R_2)C_{ext}}$$

Using the above equation for frequency equal 110 KHz, one can find the values of  $R_1$ ,  $R_2$ , and  $C_{ext}$ . Then the output was taken from the voltage on the external capacitor which has triangular wave form. A simulation was done to verify the operation of circuit and the output is shown in figure (12).

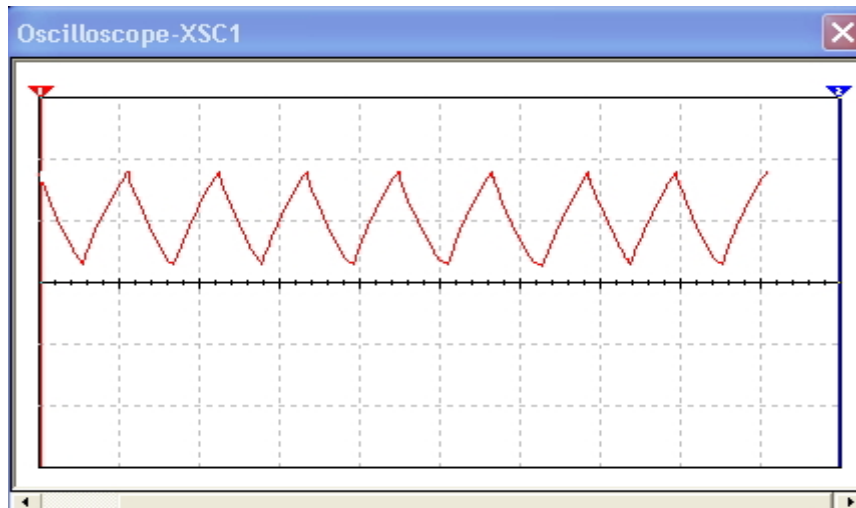

Figure 12: The output voltage on  $C_{ext}$

To avoid loading the timing circuit and changing the operating frequency, the triangular wave on the terminal of the external capacitor was buffered using OP-Amp.

## 2.2- Noise Generator:

To achieve jamming a noise signal is mixed with the triangle wave signal to produce the tuning voltage for the VCO. The noise will help in masking the jamming transmission, making it look like random "noise" to an outside observer. Without the noise generator, the jamming signal is just a sweeping, unmodulated Continuous Wave RF carrier.

The noise generator used in this design is based on the avalanche noise generated by a Zener breakdown phenomenon. It is created when a PN junction is operated in the reverse breakdown mode. The avalanche noise is very similar to shot noise, but much more intense and has a flat frequency spectrum (white). The magnitude of the noise is difficult to predict due to its dependence on the materials.

Basically the noise generator circuit consists of a standard 6.8 volt Zener diode with a small reverse current, a transistor buffer, and The National LM386 audio amplifier which acts as a natural band-pass filter and small-signal amplifier.

The output spectrum of the noise generator is shown in figure (13)

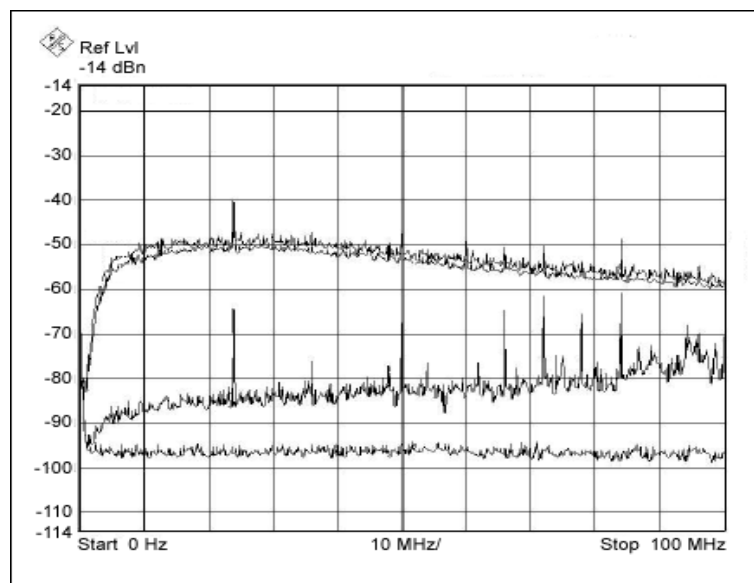

Figure 13: White-noise generator output spectrum  
(Source: [www.maxim-ic.com](http://www.maxim-ic.com))

### 2.3- Signal Mixer and DC-Offset circuits:

The triangle wave and noise signals are mixed using Op-Amp configured as summer, see figure (14). Then a DC voltage is added to the resulted signal to obtain the required tuning voltage using Diode-Clamper circuit. Figure (15) shows a diode clamper circuit with Bias. To gain good clamping the RC time

constant selected so that it's more than ten times the period of the input frequency, also a potentiometer was added to control the biasing voltage so as to get the desired tuning voltage.

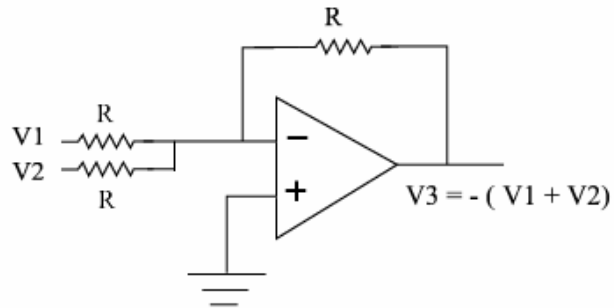

Figure 14: OP-Amp Summer Circuit

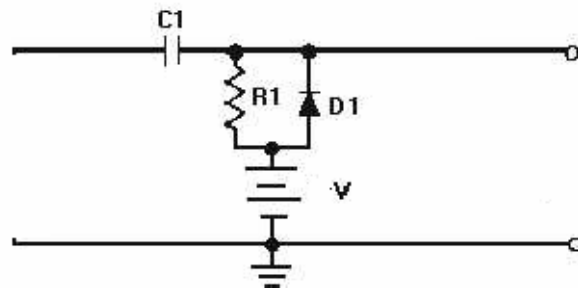
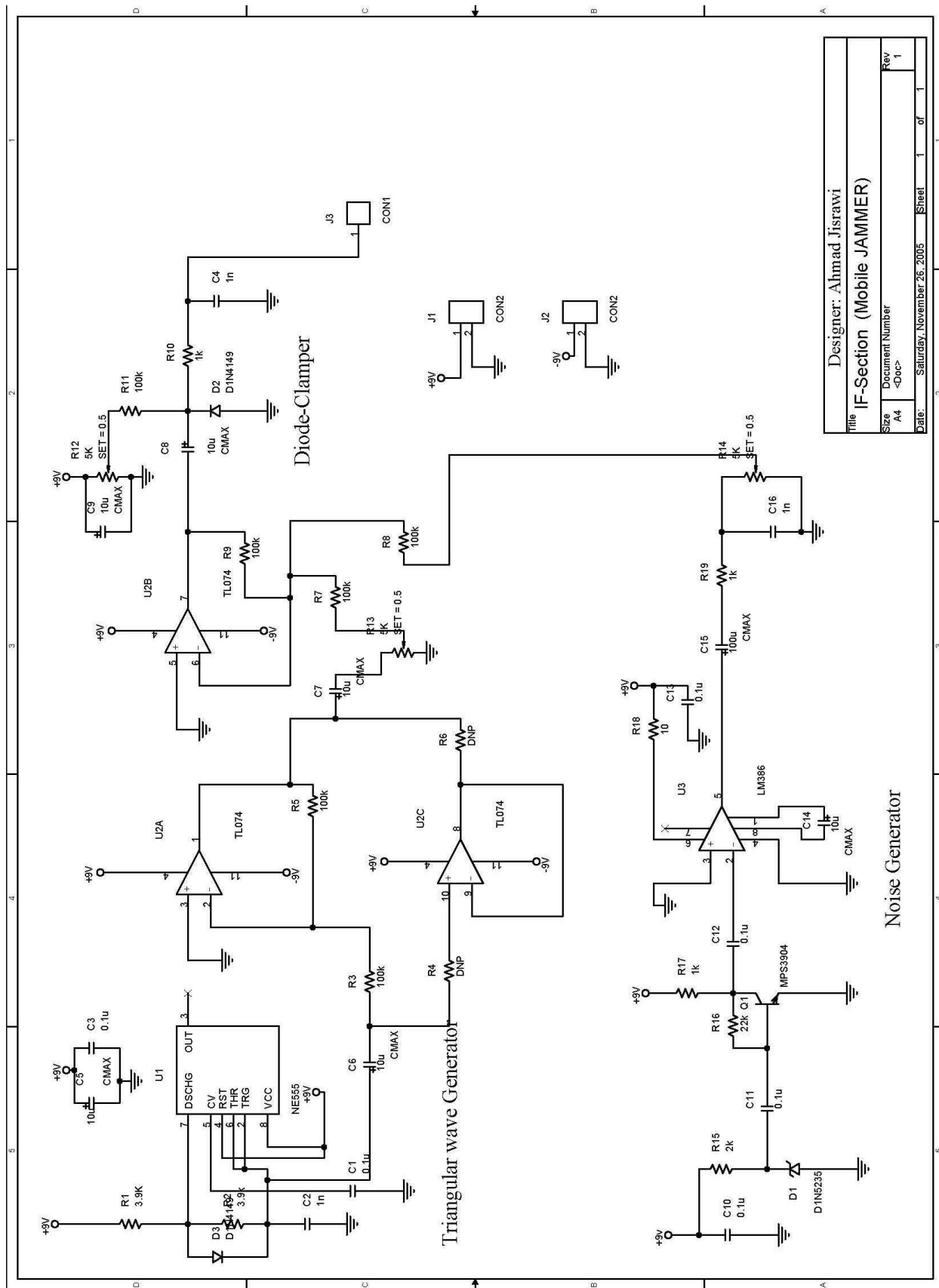

Figure 15: Positive Diode-Clamper with bias

The complete schematic for the IF section is shown in figure (16), and the printed circuit board for the IF section is shown below



Figure 16: PCB of the IF section for the mobile Jammer



Designer: Ahmad Jisrawi	
Title: IF-Section (Mobile JAMMER)	
Size: A4	Document Number: <Doc>
Date: Saturday, November 26, 2005	Sheet: 1 of 1
Rev: 1	

Figure 16: The complete schematic for the IF section



### 3- Power Supply

The mobile jammer was designed for fixed use, and to take its power from the regular 220V AC wall outlets. The IF & RF sections of the jammer require +5, +9, and -9 DC Voltages. So a dc-dual polarity power supply should be designed.

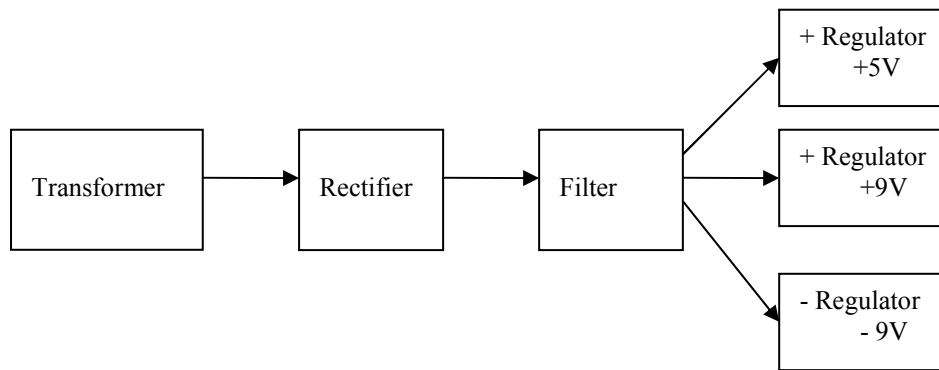

Figure 17: Block diagram of dual polarity power supply

The basic parts for a power supply are rectifier, filter, and regulator. The rectifier converts the ac input voltage to a pulsating dc voltage and can be either half wave rectifier and full wave rectifier, the one we use is the full wave rectifier which has the advantage that it allows unidirectional current to the load during the entire cycle of the input voltage and the result of the full wave rectification is an output voltage with a frequency twice the input frequency that pulsates every half-cycle of the input. The average value for a full wave rectifier for a sinusoidal input is given by:

$$V_{AVG} = 2 * V_P / \pi$$

The full wave rectifier used in this project is a full-wave bridge rectifier, which uses four diodes the peak output is given by the:  $V_P = V_{Psec} - 1.4$ , where  $V_{Psec}$  is the output voltage across the secondary winding of the transformer. In the project the transformer used is 220/12, 1.5 A rating, so  $V_{AVG} = 11$  V and  $V_P = 15.88$  V.

The second part of the power supply is the filter which eliminates the fluctuations in the output of the full wave rectifier so as to produce a constant dc voltage, the filter is

simply a capacitor and its chosen to be as large as possible to minimize voltage ripple in the output.

The final part of the power supply is the regulator and it is used to provide the desired constant dc output that is basically independent of the input voltage. Single chip regulators were used to give +5, +9, and -9 dc voltages.

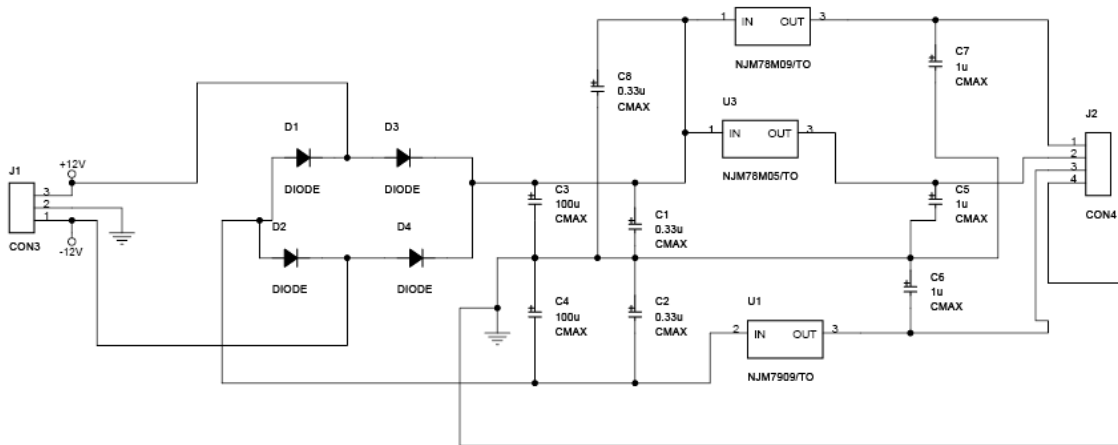

Figure 18: Circuit schematic of the power supply

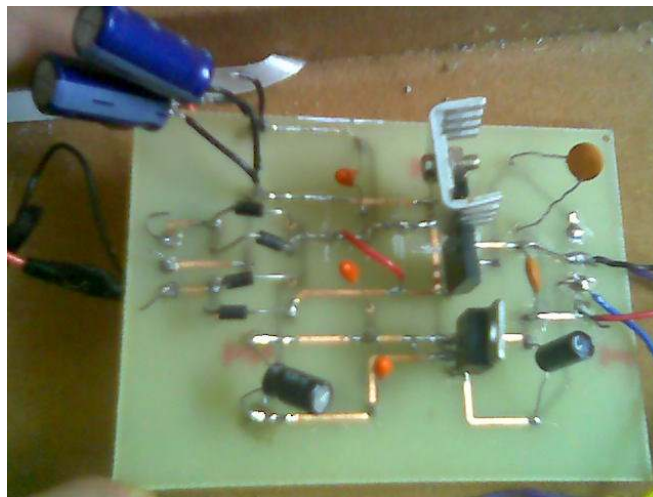

Figure 19: PCB of the power supply

## **Conclusion:**

In this project a GSM-900 Mobile Jammer was designed and built. The project was tested against the two GSM-900 Networks in Jordan (i.e. Fastlink and Mobilecom) and has proven success with average range of 10 m.

I faced a problem with tuning the VCO to the desired range, due to power supply variation with load current, so to improve the jammer a more stable power supply should be designed for robust operation of the device, also the power supply was not capable to deliver the needed current for the power amplifier and this the reason for the actual coverage range of the device was not the same as designed for.

Testing in different location shows the dependent of the jamming range on the signal strength, for instance in low GSM coverage area the jamming range exceed 20 m. In general the jamming attack was protected by network signal power, and having large power jamming device the GSM network will be jammed for sure, from this observation it can be concluded that the protection against jamming attack in the GSM system was very weak and couldn't withstand the simplest jamming techniques.

The main disadvantage of the mobile jammer is that the transmission of the jamming signal which is prohibited by law in many countries, for instance the fines for this offense can range as high as 11,000 \$.Despite the legal issues the transmission of high power signal may affect the operation of some critical devices, such as hearing impairment hardware solution. These disadvantages will constrain the use of mobile jammer.

## References:

- [1] Mobile & Personal Communications Committee of the Radio Advisory Board of Canada,  
“Use of jammer and disabler Devices for blocking PCS, Cellular & Related Services”  
<http://www.rabc.ottawa.on.ca/e/Files/01pub3.pdf>
- [2] Braun, T.; Carle, G.; Koucheryavy, Y.; Tsaoussidis, V., Wired/Wireless Internet  
Communications, Third International Conference, WWIC 2005, Xanthi, Greece, May 11-  
13, 2005, Proceedings, p188.
- [3] John Scourias, Overview of the Global System for Mobile Communications,  
<http://cnga.uwaterloo.ca/~jscouria/GSM/gsmreport.html#1>
- [4] Rick Hartley, RF / Microwave PC Board Design and Layout,  
[www.jlab.org/accel/eecad/pdf/050rfdesign.pdf](http://www.jlab.org/accel/eecad/pdf/050rfdesign.pdf)
- [5] [http://www.mumor.org/public/publications/ISCAS\\_2004\\_MuMo\\_Receiver.pdf](http://www.mumor.org/public/publications/ISCAS_2004_MuMo_Receiver.pdf)
- [6] Siwiak, K., Radiowave Propagation and Antennas for Personal Communications, Artech  
House, 2nd.ed, p138.
- [7] Pozar, D. M., Microwave Engineering, John Wiley and Sons, 2nd.Ed, p198.
- [8] Gopalan, K. Gopal, Introduction to Digital Microelectronic Circuits, Irwin, New York,  
1996. pp. 496-500.
- [9] Floyd, Electronic Devices, Prentice Hall, 5th. Ed, pp.60-85
- [10] Horowitz, P.; Hill, W., the Art of Electronics, 2nd. Ed, Cambridge University Press.